

MODEL : PK20

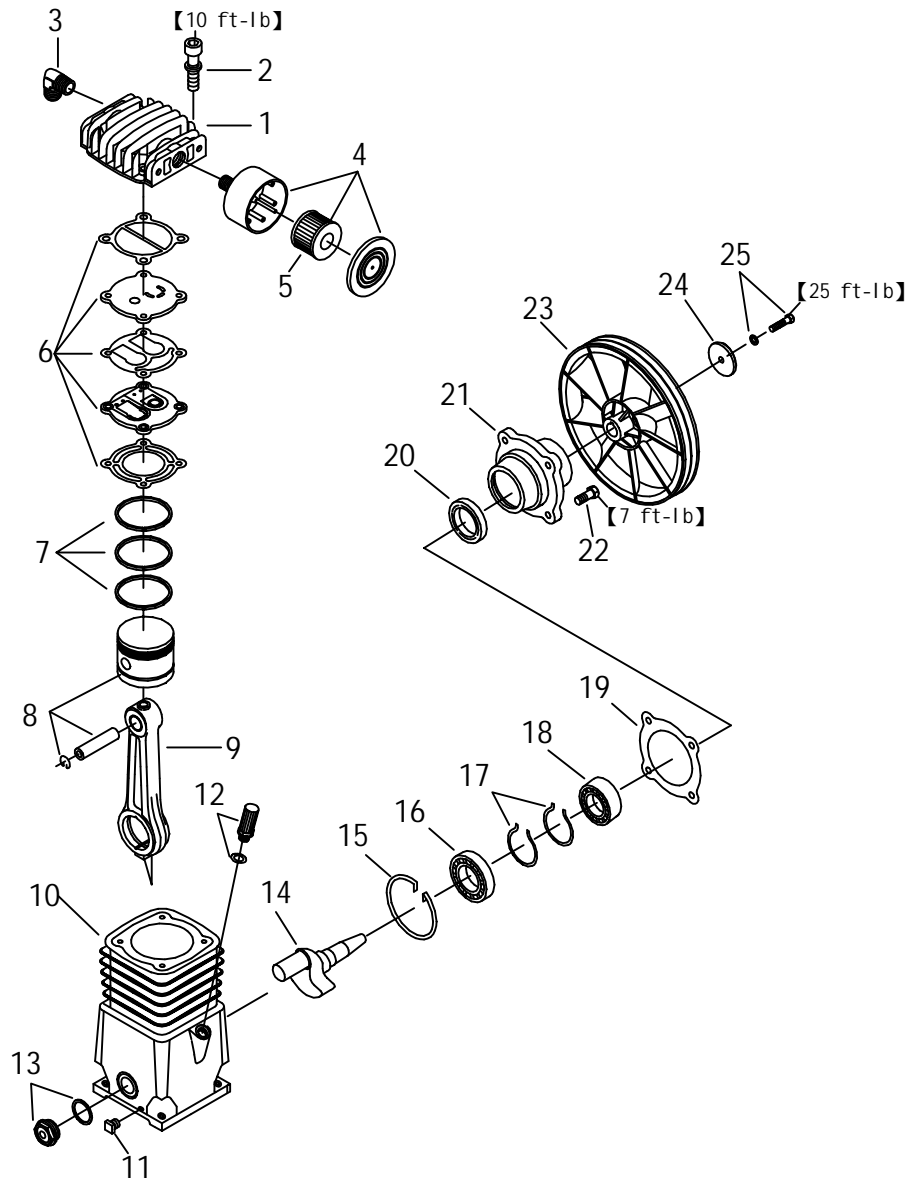

SPARE PARTS LIST

NO : MF-1201

REF. NO.	DESCRIPTION	PART NO.	QTY.	REF. NO.	DESCRIPTION	PART NO.	QTY.
1	Cylinder head	3101042	1	14	Crankshaft & balancer	3304075A	1
2	Allen bolt set	3B01-M06*040V	4	15	Bearing snap ring	2N43-021	1
3	Elbow	2N06-04T04H	1	16	Bearing	2N35-6205	1
4	Air filter set	2140019A	1	17	Crankshaft snap ring	2N42-S24	2
5	Filter element	2142013	1	18	Bearing	2N35-6004Z	1
6	In. & Ex. valve assembly	3B13-AC0765C	1	19	Bearing seat gasket	2G06-009	1
7	Piston ring set	3B32-65N	1	20	Oil seal	2N50-TC20*35*07	1
8	Piston set	3B31-65N	1	21	Bearing seat	3311028A	1
9	Rod	2315041	1	22	Hexagon bolt	2B00-SM06*020	4
10	Crankcase	3301053	1	23	Pulley	3PBF-075A120	1
11	Oil draining plug	2N33-001	1	24	Plate washer	2B30-08*35*35	1
12	Breather set	2339009A	1	25	Hexagon bolt set	3B00-SM08*030V	1
13	Oil sight gauge set	2303021B	1				