

ITEM NO.	PART NO.	DESCRIPTION	QTY.
3	F31826	1/4"-NPT 1500# FLAT FLANGE	4
4	F31840	3/4"-NPT 1500# FLAT FLANGE	2
5	F30316	2"-NPT 1500# FLAT FLANGE O-RING	1
6	F30316	2"-NPT 1500# FLAT FLANGE O-RING	1
7	F12430	1 1/2"-NPT 1500# RADIAL FLANGE	1
8	A76788	7GA SADDLE	2
9	A84278	4GA TOPPLATE	2
10	A84282	4GA BRACKET	3
11	A97713	4GA BRACKET W/ 1" HOLE	1
12	A20910	ASME DATA PLATE	1

APPROVED BY: \_\_\_\_\_ DATE: \_\_\_\_\_

ITEM #5 HAS 2NPT O-RING PIPE PLUG  
 ITEM #6 HAS 2NPT X 3/4NPT O-RING BUSHING REDUCER WITH PLASTIC PLUG  
 ALL OTHER OPENINGS HAS PLASTIC SHIPPING PLUGS INSTALLED

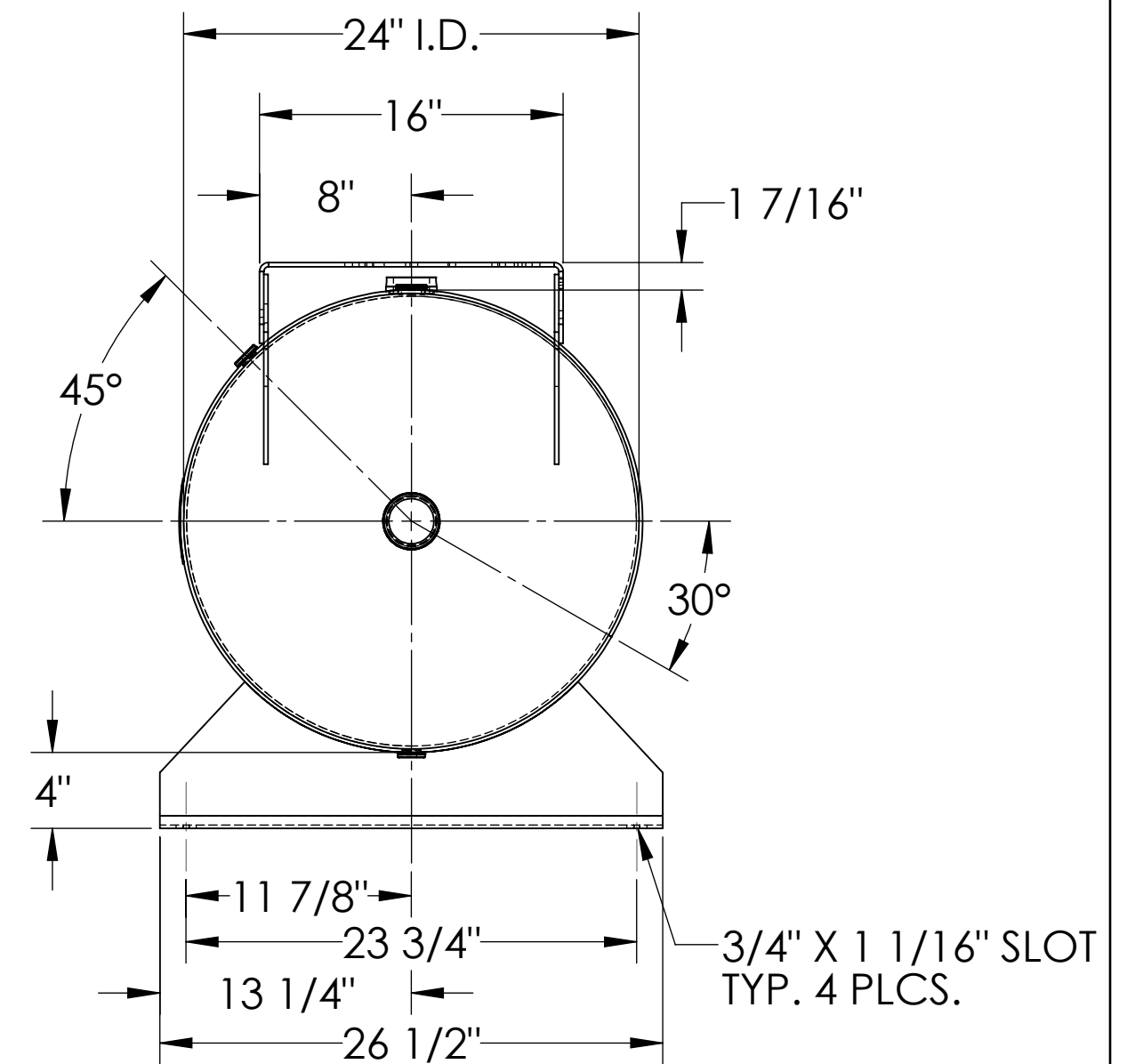
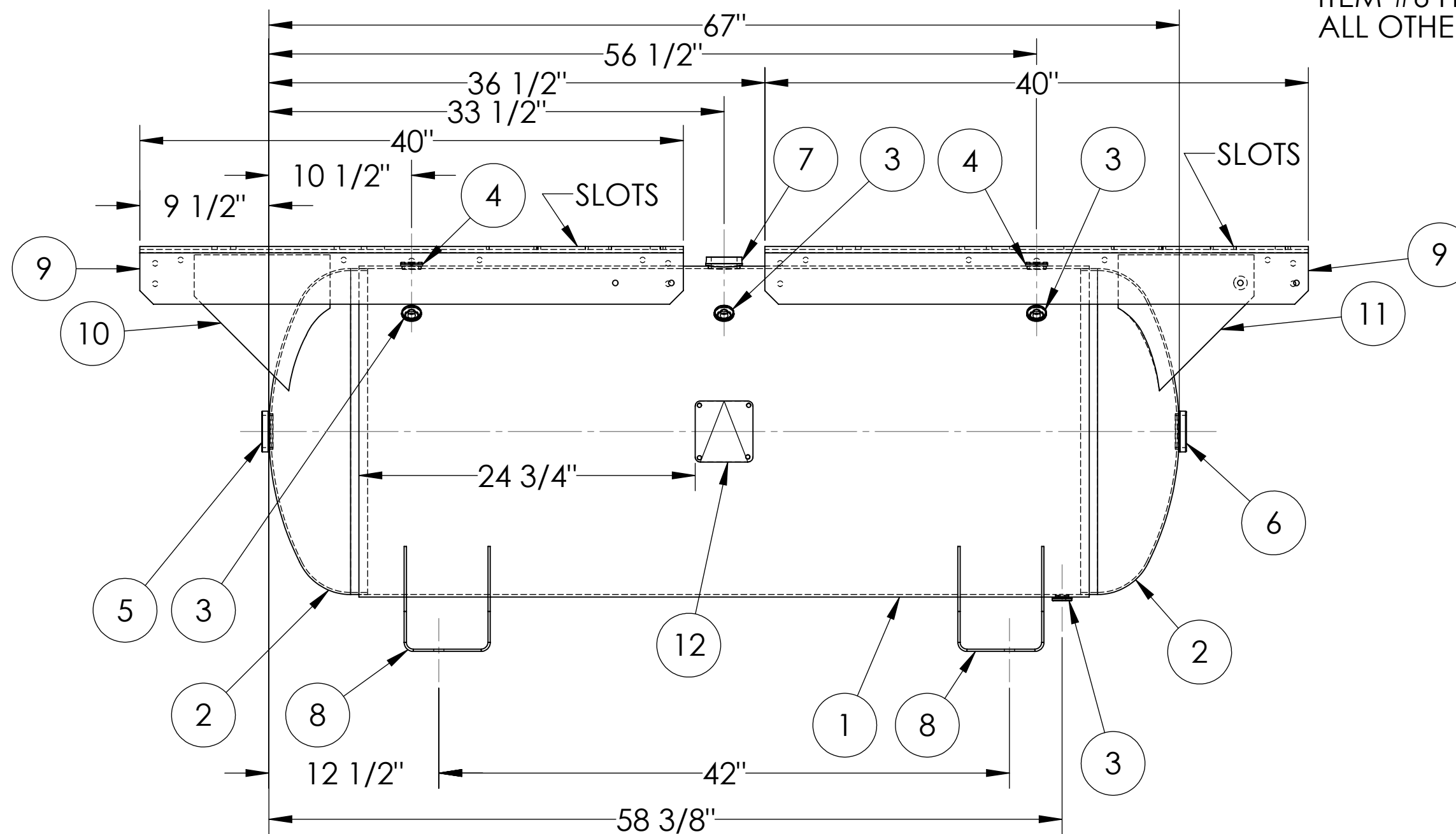

NOTES:

SPECIFICATIONS

I.D. 24 LGTH. 67 MAWP 200 PSI @ 400°F  
 WT. 472 LBS.  
 S.A. 37.5 SQ.FT.  
 GAL. 120 CU.FT.16.4 CRN: E7400.2C  
 CODE: ASME Section VIII, Div.1, LATEST EDITION & ADDENDA EXMT UG-20(f) CORR ALW 0 SH 0 HD  
 STD. TOLERANCES: M-2461 (UNLESS OTHERWISE NOTED) WELD DETAILS: M-1932



**HORIZONTAL AIR RECEIVER**  
**COMPRESSED AIR SYSTEMS IAT-310079**

FILE LOCATION: O:\SolidWorks\3000\310079

DRAWN BY: \_\_\_\_\_ DATE: \_\_\_\_\_

APPR. BY: \_\_\_\_\_ DATE: \_\_\_\_\_

SCALE: NONE  
 DRWG NO. **310079**

CODE 2013 APPROVED DP  
 RELEASED FOR PRODUCTION  
 Q.C. \_\_\_\_\_ DATE \_\_\_\_\_

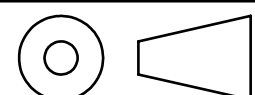

ZONE	REV.	BY	DESCRIPTION	DATE	APP.